



HIGH  
DOOR  
INSULATION



# DYNASEAL



# CHARACTERISTICS

**Transom** composed of:  
- Back side 20/10 galvanized steel and front cover 15/10 galvanized steel.  
- Option : powder coated 180 micron

**Magnetic sealing gasket**

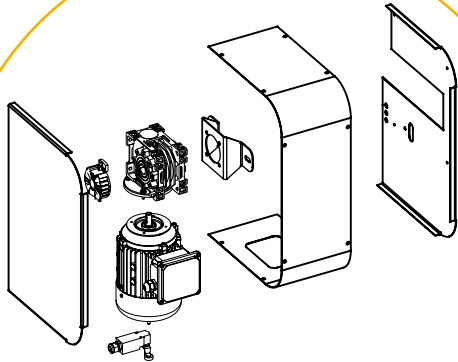

**Three phases motors**  
230/400V in direct drive.  
- Absolute encoder

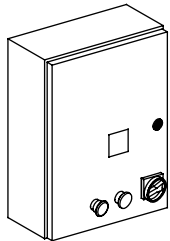

## Inverter control box

- Painted metal box Dim. 300x500x130
- Emergency stop button
- Switch ON-OFF
- Single phase Inverter control card max power 2.2 kW
- Three phases Inverter control card max power 4kW
- Cables with connector M8/M12 IP65
- Status/Error display
- Automatic closing
- Position relay
- Interlock function
- Supplementary function (see instruction manual)

**PVC curtain**  
with transparent sections / windows

**Side columns** with extruded black polyethylene profile (1'000'000 molecules)

**Self-lubricant guide** with sealing gasket, no service is required

# TECHNICAL DATA



LOW PERMEABILITY



STERILE ENVIRONMENT



SELF-REPAIRING



OXYGEN-REDUCED ENVIRONMENTS



CONTROLLED PRESSURE ENVIRONMENTS



WIND RESISTANCE



GRAVITY TECHNOLOGY

**Dynaseal** is a self-repairing door conceived and designed for environments for fruit ripening and for premises for smoking meat thanks to its sealing system. Thanks to its special compact frame and the sliding system, this door has a low permeability to be suited for controlled environments. The Dynaseal door guarantees wind resistance up to class 5.



WATCH THE VIDEO!

<b>FUNCTIONING</b>	AUTOMATIC
<b>CYCLES PER HOUR</b>	> 200
<b>CYCLES TEST</b>	1.000.000
<b>SPEED</b>	up to 2,5 m/s
<b>WIND RESISTANCE* differential pressure</b>	Class EN 12424
<b>WIND SPEED DURING DOOR OPENING</b>	< 20 m/s (60 km/h)
<b>SOUNDPROOFING standard</b>	15 dB Rw (ISO 717)
<b>WATER RESISTANCE</b>	0,11 kPa for door closed Class 3 - EN12426
<b>AIR PERMEABILITY</b>	<b>Class 5 - EN 12426:2001</b>
<b>OPERATING TEMPERATURE OPERATING ENVIRONMENT</b>	-10°C to +70°C

\*This door, according to the regulations 13241/CE, requires an half-yearly check

## SEALING SYSTEM

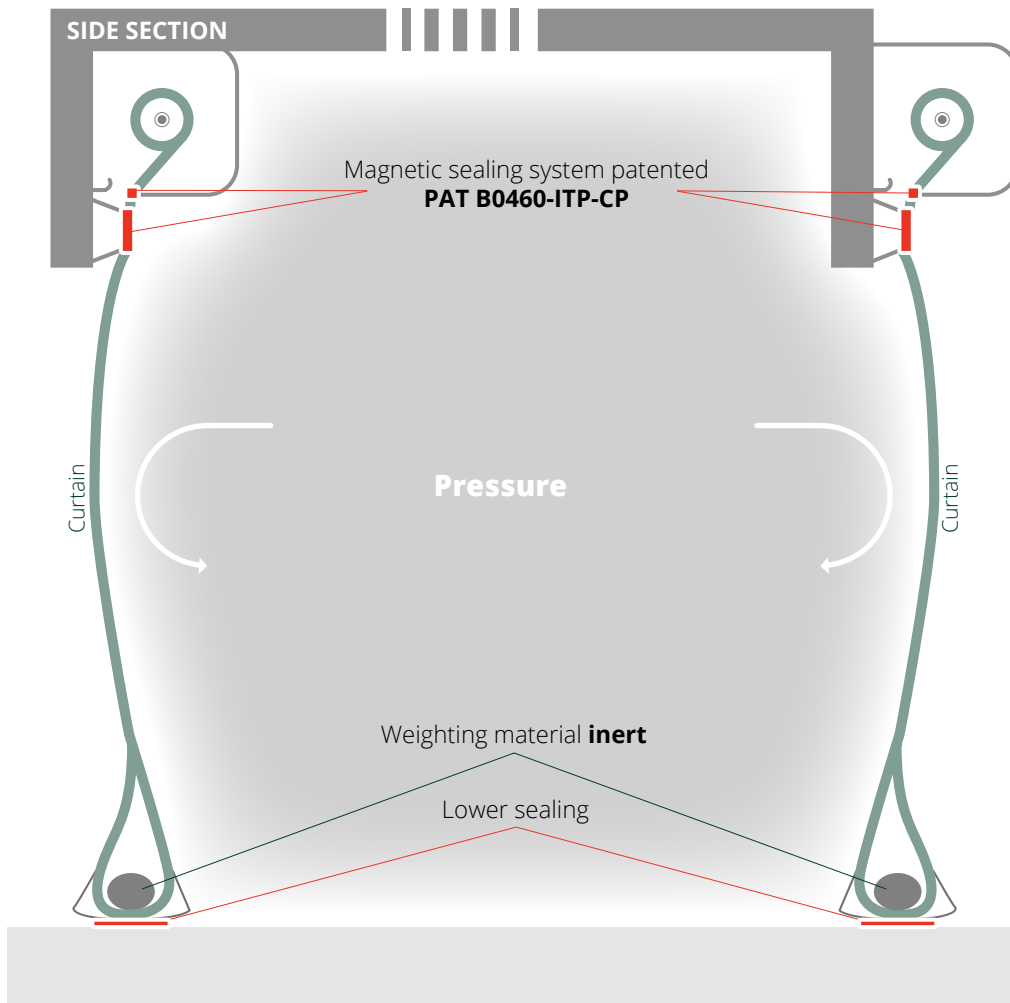

TEST DATA WITH PRESSURE  
Door dimension 3500 (L) x 3000 (H) UNI EN 12427:2002

Pa	m³/h	-Pa	m³/h
10	4,82	-10	9,80
20	6,30	-20	10,68
30	13,35	-30	14,48
40	11,64	-40	19,12
50	12,67	-50	19,91

### VIEW FROM ABOVE

Magnetic sealing system patented **International PAT B0510-EPP-CP**

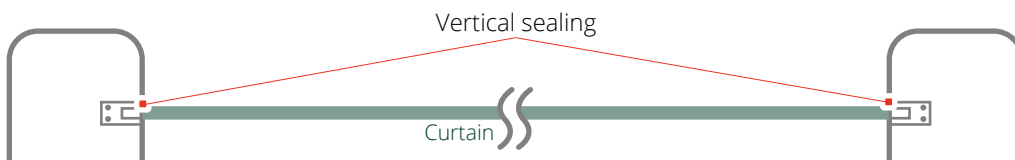

# UNI EN 12426:2001

**CLASSIFICATION:** The air permeability of an evidence shall be declared according to the given classes in Table 1.  
An evidence belongs to a specific class, if the test results measured respecting the EN 12427 do not exceed the value specified for that class in Table 1.

**TABLE 1 - Air permeability classes**

Class	Air permeability $\Delta p$ at a pressure of 50 Pa [m/mh]	Specification
0	-	No benefits determined
1	24	-
2	12	-
3	6	-
4	3	-
5	1,5	-
6	-	Exceptional; agreement between manufacturer and buyer for infiltration and pressure

**NOTES** Where conditions greater than 50 Pa are applied, the situation must be considered exceptional and greater than class 5 and should be the subject of contractual approval between manufacturer and purchaser.

# UNI EN 12427:2002

**TEST PREPARATION**

- The evidence shall be installed in accordance with the manufacturer's published or referenced installation instructions.
- The evidence shall consist of components that conform in detail to the manufacturing quality level. Wherever possible the evidence should be set up from scratch. Doors and components in stock shall be considered as newly manufactured if they comply fully with current manufacturing specifications.
- The evidence must be clean and with the surfaces dry.
- Any ventilation, drainage or discharge holes shall be taped shut or left open according to the purpose of the test and this purpose and condition shall be noted and recorded.
- In most instances, air can pass through both fixed and opening gaps.
- For minimum evidence dimensions see Table 1

**PROSPECTUS**

	Minimal evidence dimensions
Commercial and garage doors	Width: 2 000 mm Height: 2 000 mm
Industrial doors	Width: 3 500 mm Height: 3 000 mm

# OVERALL DIMENSIONS

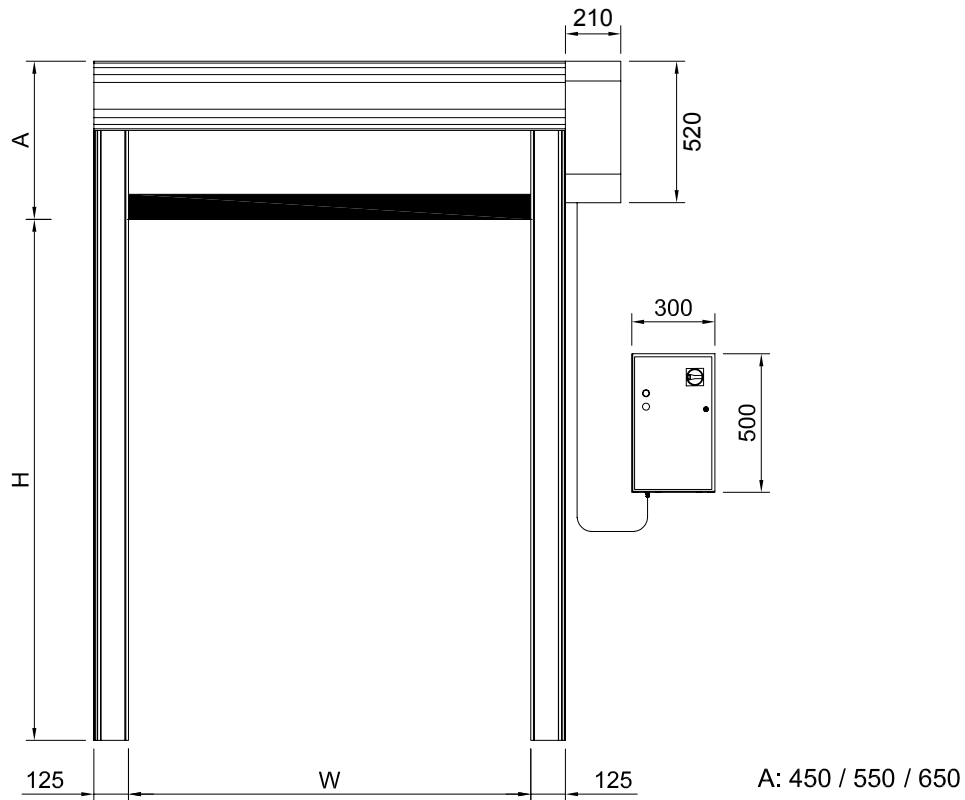

## MOUNTING METHOD

### Reveal fit mounting

In case of reveal fit, columns must be supported by 120x40 vertical galvanized steel profile supplied with the door. It's possible to mount the frontal motor.

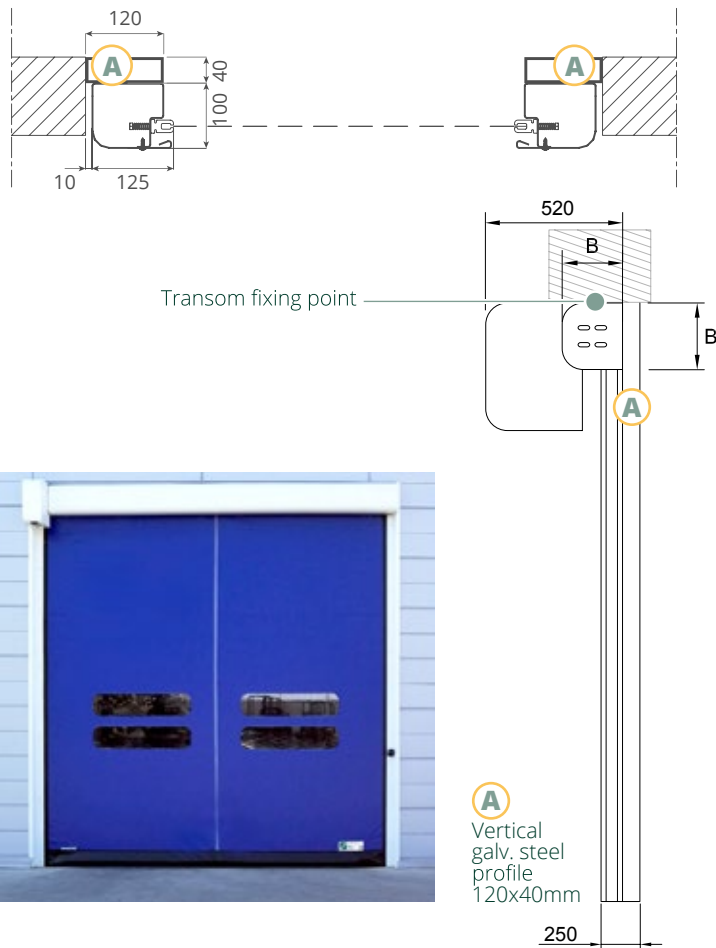

### Face fit mounting

In case of face fit, columns are fixed direct to the existing wall. Make sure there is an appropriate support.

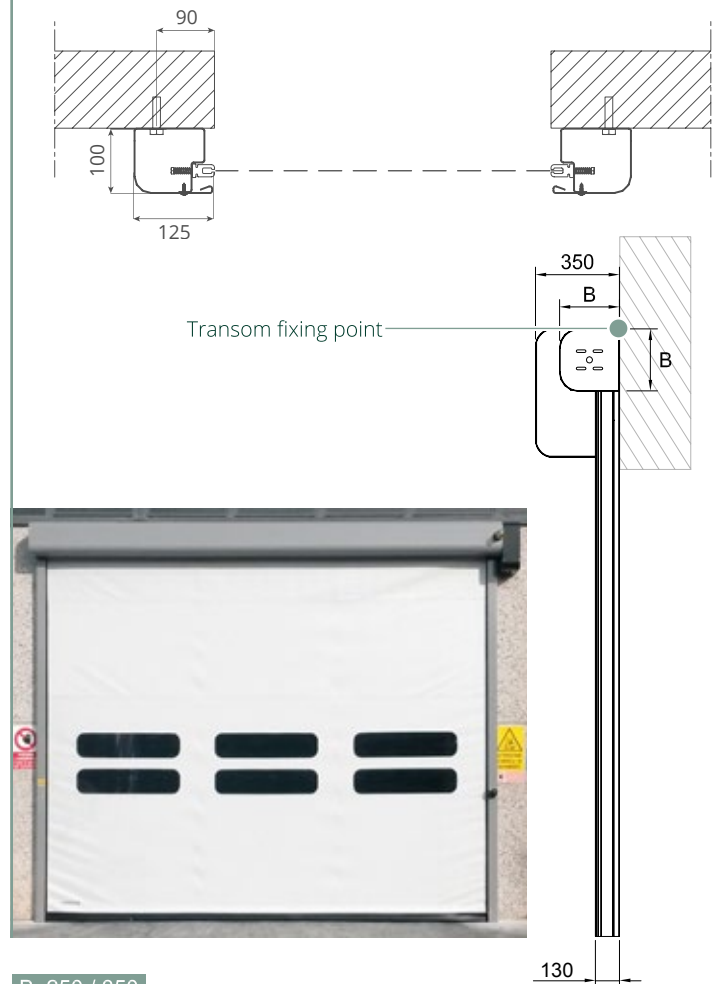

# PVC CHARACTERISTICS

## STANDARD PVC

### Composition and tests

EXTERNAL SIDE			
Material	Finishing	Color	Thick
PVC	Opaque	12 standard	0,7 mm
FABRIC			
Material	N. tarps	Title	EN 2286-2
PES	1	1100Dtex 12x12	900 g/m <sup>2</sup>
INTERNAL SIDE			
Material	Finishing	Color	Thick
PVC	Rough	12 standard	0,2 mm
<b>COLD RESISTANCE</b> ISO 4675/90 -50°C ±5			
<b>HYDROLYSIS TEST</b> 75°C 95% humidity none variation			
<b>GAS OIL TEST</b> ISO 1421 none variation			
<b>MARINE WATER TEST</b> (ISO 1421) none variation			
<b>OZONE TEST</b> ISO 3011 none crack			
<b>T. STORAGE</b> (°C) -30 +65			
<b>FLAME TEST</b> (ISO 3795) < 100 mm/min			
<b>PERFORATION</b> RINA 3.A1.2.7 (N) > 100			
<b>EXERCISE 7 days -70°C</b> ISO 6065 none variation			

### Characteristics

<b>THICK</b> ISO 2286/3 (mm) 0,9±0,1
<b>WEIGHT</b> ISO 2286/2 (kg/m <sup>2</sup> ) 0,90±0,1
<b>LOAD BREAK</b> ISO 1421 6000 N/50mm
<b>WARP EXTENSION</b> ISO 1421 4300 N/50mm
<b>TEXTURE EXTENSION</b> ISO 1421 4000 N/50mm
<b>WARP BREAK</b> dIN 53 363 (N) > 600
<b>TEXTURE BREAK</b> dIN 53 363 (N) > 530
<b>ADHESION</b> dIN EN ISO 2411 130 N/50mm
<b>EEC CONFORMITY</b> Yes
<b>SPECIFIC USE</b> industry, refrigerators, car washes, supermarkets, warehouses
<b>ASSOCIATION</b> -

### Colors

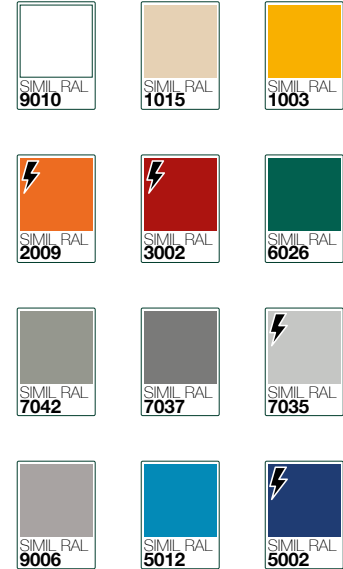

⚡ Antistatic available

## INSULATED PVC

### Composition and tests

EXTERNAL SIDE			
Material	Finishing	Color	Thick
PVC	Straight	4 standard	0,5 mm
FABRIC			
Material	N. tarps	Title	EN 2286-2
PES	1	1100Dtex 12x12	1350 g/m <sup>2</sup>
INTERNAL SIDE			
Material	Finishing	Color	Thick
PVC	Sponge	4 standard	7 mm
<b>COLD RESISTANCE</b> ISO 4675/90 -10°C ±5			
<b>HYDROLYSIS TEST</b> 75°C 95% humidity none variation			
<b>GAS OIL TEST</b> ISO 1421 none variation			
<b>MARINE WATER TEST</b> (ISO 1421) none variation			
<b>OZONE TEST</b> ISO 3011 none crack			
<b>T. STORAGE</b> (°C) -30 +65			
<b>FLAME TEST</b> ISO 3795 cl 2, NFPA 701 test 2			
<b>PERFORATION</b> RINA 3.A1.2.7 (N) > 100			
<b>EXERCISE 7 days -70°C</b> ISO 6065 none variation			

### Characteristics

<b>THICK</b> ISO 2286/3 (mm) 7,0±0,1
<b>WEIGHT</b> ISO 2286/2 (kg/m <sup>2</sup> ) 1,7±0,1
<b>LOAD BREAK</b> ISO 1421 6000 N/50mm
<b>WARP EXTENSION</b> ISO 1421/V1 3000 N/50mm
<b>TEXTURE EXTENSION</b> ISO 1421/V1 2800 N/50mm
<b>WARP BREAK</b> dIN 53 363 300 N
<b>TEXTURE BREAK</b> dIN 53 363 300 N
<b>ADHESION</b> PA 09.03 (internal) 15 N/cm
<b>THERMAL CONDUCTIVITY</b> 0,03782 W.m <sup>-1</sup>
<b>ISOLATION INDEX</b> Rw= 17,5 dB
<b>EMPLOYMENT</b> industry, refrigerators, car washes, supermarkets, warehouses
<b>ASSOCIATION</b> -

### Colors

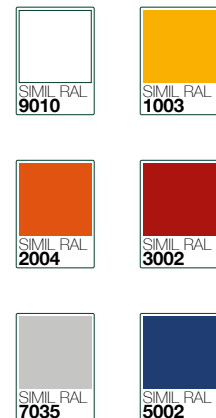

**MEASUREMENT OF SOUNDPROOFING POWER**  
R - UNI EN ISO 10140-2 - UNI EN ISO 717-1

	Source	Receiver
Volume (m³)	86,0	70,5
Temp. (°C)	21,0	21,0
Volume (m³)	86,0	70,5
FREQ. Hz	R dB	U dB
100	14,9	1,8
125	7,5	1,7
160	8,2	1,5
200	8,7	1,6
250	8,8	1,3
315	8,6	1,2
400	10,7	1,2
500	11,7	1,1
630	13,5	1,1
800	15,4	1,1
1000	16,9	1,0
1250	18,8	1,0
1600	20,4	1,0
2000	21,2	1,0
2500	21,8	1,0
3150	22,6	1,0
4000	22,9	1,0
5000	23,0	1,0
Rw	17 dB	
C	-1 dB	
Ctr	-3 dB	
K	2,00 - 95%	

Evaluation according to ISO 717-1 in the band 100 ÷ 3150 Hz based on laboratory measurements

**SAMPLE AREA**  
S = 1,50 m²

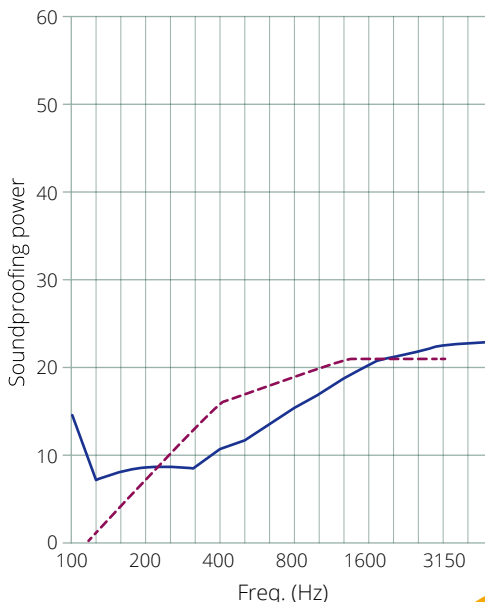

# CRISTAL CHARACTERISTICS

PVC SUPERCLEAR



**WINDOWS - CRISTAL**  
TECHNICAL DATA

Article	SUPERCLEAR 1.2 mm FR
---------	----------------------

Technical Specifications	Standards	Unit	Values
Thickness	-	mm.	1.2
PVC total weight	-	g/m <sup>2</sup>	1200
Ligth transmission	JIS K - 7361	%	97.3
Tensile strength <i>Lenghtwise MD</i>	JIS K - 6732	N	26.1
Tensile strength <i>Crosswise TD</i>	JIS K - 6732	N	24.3
Tear strength <i>Lenghtwise MD</i>	JIS K - 6732	N	63.4
Tear strength <i>Crosswise TD</i>	JIS K - 6732	N	63.9
Elongation <i>Lenghtwise MD</i>	JIS K - 6732	%	377
Elongation <i>Crosswise TD</i>	JIS K - 6732	%	378
Cold crack resistance	JIS K - 6772	°C	-45
Flame retardancy	-	-	sì
Hardness	-	-	4.0S
Standard length	-	m	30
Standard width	-	m	1.37



# OPTIONAL ACCESSORIES



## RADAR



OPENING POINTING RADAR  
TOF/SPOT  
for internal use only



INFRARED RADAR  
with cross-movement  
adjustment



INFRARED RADAR  
motion and presence  
(pedestrian/forklift) radar

## TRAFFIC LIGHTS



GREEN FIXED STANDARD  
traffic light



RED FIXED STANDARD  
traffic light



LED TRAFFIC LIGHT  
with countdown

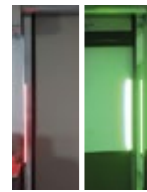

LED TRAFFIC LIGHT BARRIERS  
(connection card included)

## BUTTONS



OPENING GREEN BUTTON  
with box



OPENING BLACK BUTTON  
with box



FREEZE STOP BUTTON  
with box



NO TOUCH BUTTON



TRAFFIC LIGHT  
BUTTON



WIND  
GAUGE



KEY  
SELECTOR



REMOTE  
CONTROL



BOLLARD  
B-PROTECT

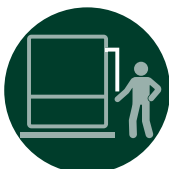

PULL CORD  
SWITCH



MAGNETIC LOOP  
DETECTOR

Quality products since 1997

**BMP EUROPE HIGH SPEED DOORS**  
Strada della Freisa 1 - Villanova d'Asti 14019 (AT)  
+39 0141 948843  
[www.bmpdoors.com](http://www.bmpdoors.com) - [info@bmpeurope.eu](mailto:info@bmpeurope.eu)

09/2021